

## THEORETICAL PREDICTION OF THE PORE SIZE OF WOVEN, KNITTED AND NONWOVEN FILTER FABRICS

التنبؤ الرياضي بقطر المسام في أقمشة المرشحات المنسوجة والتريكو والغير منسوجة

BY

HEMDAN A. ABOU - TALEB

Textile Engineering Dept., Faculty of Engineering, Mansoura  
University, Mansoura, Egypt

الخلاصة - البحث الحالي هو دراسة لامتكانية التنبؤ بقطر المسام في أقمشة المرشحات . وقد أمكن التوصل إلى عدة معادلات رياضية للتنبؤ بقطر المسام في أقمشة المرشحات المنسوجة والتريكو والغير منسوجة . من ناحية أخرى فإن التجارب العملية لقطر المسام قد أمكن الحصول عليها بواسطة استحداث جهاز بسيط تم إنشاؤه بواسطة الباحث مستخدماً طريقة ضغط الفقاعة . النتائج المحسوبة بواسطة المعادلات النظرية التي قد تم التوصل إليها وجد أنها قريبة إلى حد كبير من النتائج العملية المقاسة على الجهاز السابق ذكره .

**ABSTRACT** - The present investigation deals with the study of pore size of filter fabrics. Theoretical expressions are derived for calculating the pore equivalent diameter of woven, knitted and nonwoven filter fabrics. Experimental results were obtained by using a new simplified apparatus. This apparatus has been designed by the author on the base of bubble-pressure method. The derived relations were found to be fairly close to those observed experimentally.

### 1. INTRODUCTION

The capture of solid particles by filter fabrics finds widespread applications in the industrial processes where the final product must be recovered or where emissions to the surrounding environment need to be controlled. Also when studying the air permeability, filtration performance, thermal conductivity and other properties of fabrics, it is necessary to know pore diameter and porosity. For assessing the quality of filter or waterproofed fabrics, it is necessary to have a measure of the size of the pores. An estimate of pore size is also generally useful in the choice of fabrics for many purposes.

Fabric pore diameter is commonly measured by means of microscope and also it could be measured by the method of geometrical probabilities [1]. In these methods, for obtaining accurate results, large number of measurements of pores must be carried out and more time can be lost. A method which has a particular application in the field of testing for waterproofness has been proposed by Bartell [2]. The method consists of determining the pressure necessary to force out of the pores of the fabric a liquid which wets it completely. This pressure, the bubble pressure, is determined by the shape of hole, its size and the surface tension of the liquid. The hydrostatic head test [3], which is one of the more commonly used measures of waterproofness, is made by subjecting one face of a specimen to a steadily increasing hydrostatic pressure, the pressure at which drops of water penetrate the specimen at the third place is recorded as the hydrostatic head. This result depends on the pore size and shape and the efficiency of the waterproof finish applied to the fabric. This test is of a very similar nature to the test for bubble pressure.

Previous work [1-7] has concerned with determining fabric pore diameter experimentally and not theoretically especially for knitted and nonwoven fabrics. And very little work has been done on the effect of fabric construction for predicting pore size of filter fabrics. The purpose of this paper is to fill this gap and to design a new simplified apparatus to measure the pore equivalent diameter of filter fabrics.

## 2. THEORETICAL WORK

### 2.1 Woven Fabrics:

Kykin and Salaveov [8] calculated the dimensions of pore void for woven fabric shown in Fig.1 as follows:

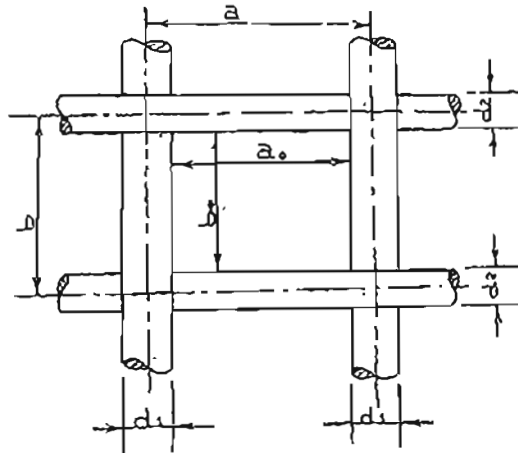

Fig.1. Geometrical model of woven fabric

$$a_0 = a - d_1 = \frac{100}{n_1} - d_1 \quad , \quad \text{mm} \quad \dots(1)$$

$$b_0 = b - d_2 = \frac{100}{n_2} - d_2 \quad , \quad \text{mm} \quad \dots(2)$$

where  $n_1, n_2$  - number of warp and weft yarns per 100 mm,

$d_1, d_2$  - diameter of warp and weft yarns respectively in mm,

Jokhena [5] suggested the harmonic mean method for calculating the pore equivalent diameter ( $d_e$ ) of woven fabric as follows:

$$d_e = 2 \left( \frac{1}{a_0} + \frac{1}{b_0} \right) \quad , \quad \text{mm} \quad \dots(3)$$

2.2. Knitted Fabrics:

2.2.1 Nomenclature

- d - Yarn diameter , mm
- A - Wale spacing, mm
- B - Course spacing, mm

2.2.2 Calculation of pore area

Several knitted fabrics of rib 1X1 are produced with different yarn diameters, wale spacings and course spacings. The planed structure of the stitch is shown in Fig.2. The axis of the yarn in the planed condition is composed of circular arcs and straight lines. The structure repeat of rib 1X1 stitch with height B and width A can be taken into consideration for calculating the pore equivalent diameter as follows:

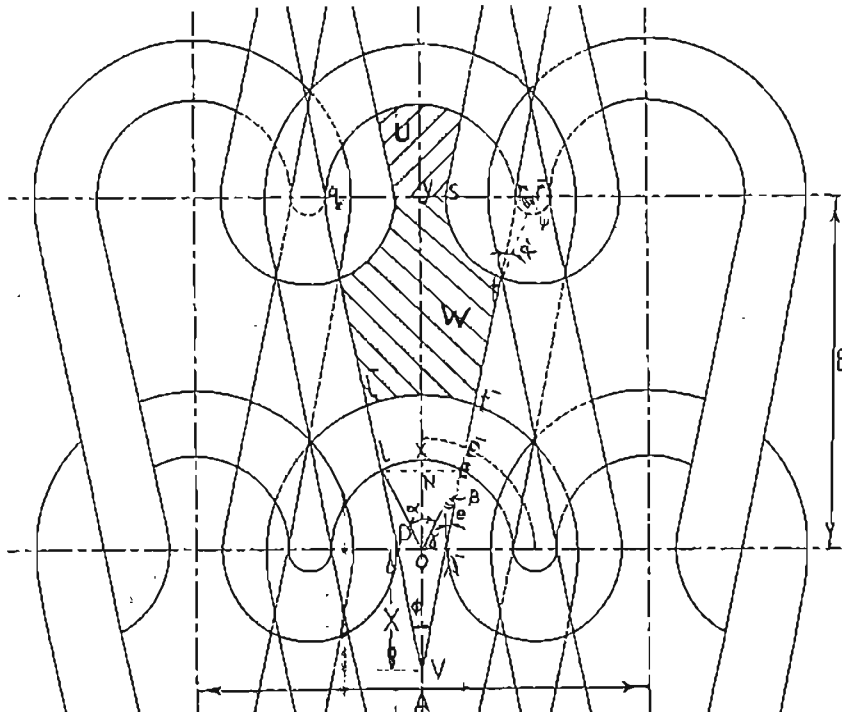

Fig.2. The planed structure of knitted fabric

From triangle OAE:

$$\beta = \sin^{-1} [\sin (90 + \theta) \cdot (A/2 - 2d)/3] / (A/4 - d/2)$$

$$\theta = \tan^{-1} d/B \quad , \alpha = 2 (\beta + \theta)$$

$$\gamma = 180 - (B + \theta + 90)$$

Area of trapezoid  $\hat{A}ELP = 0.5 OE \sin \gamma [2 (A/2 - 2d)/3 + 2OE \cos \gamma]$   
 Segment area  $EXL = 0.5 OE^2 [(T\alpha/180) - \sin \alpha]$   
 where  $OE = (A/4 - d/2)$

$\therefore$  Area  $U =$  trapezoid area  $\hat{A}ELP +$  Segment area  $EXL$   
 From triangle  $r\hat{t}t$ ;  
 $\hat{\alpha} = \sin^{-1} [\sin(90 + \theta) \cdot (A/2 - 2d)/6] / [d + (A/2 - 2d)/6]$   
 $\psi = 180 - (\hat{\alpha} + \theta + 90)$   
 Area of sector  $\hat{r}ts = T\psi [d + (A/2 - 2d)/6]^2 / 360$   
 Area of triangle  $\hat{r}tr = \sin \psi (A/2 - 2d) [d + (A/2 - 2d)/6] / 12$   
 Area  $rts =$  area  $\hat{r}ts -$  area  $\hat{r}tr$   
 From triangle  $vry$ :  
 $OV = O\hat{A} \cdot B/d = B(A/2 - 2d) / 3d$   
 Area of ring  $EL\hat{L}T = (T/180) \cdot \sin^{-1} O\hat{A} [(VE + d)^2 - (VE)^2] / V\hat{A}$   
 where  $VE = [OE^2 + OV^2 - 2OE \cdot OV \cdot \cos(90 + \gamma)]^{1/2}$   
 $V\hat{A} = [(OV^2 + (O\hat{A})^2)]^{1/2}$   
 Area of trapezoid  $\hat{A}pqr = B(2O\hat{A} + d)$   
 Area  $W =$  area  $\hat{A}pqr - [\text{area } M + \text{area } EL\hat{L}T + 2(\text{area } rst)]$   
 Pore area = area  $U +$  area  $W$  ... (4)

### 2.2.3 Calculation of pore circumference

Pore circumference =  $LXE + 2E\hat{A} + 2st + st\hat{t} + \hat{L}\hat{t}$  ... (5)  
 where  $LXE = (2T \cdot VE / 360) \cdot 2 \sin^{-1} O\hat{A} / V\hat{A}$   
 $E\hat{A} = [(O\hat{A})^2 + (OE)^2 - 2O\hat{A} \cdot OE \cos \gamma]^{1/2}$   
 $st = T [d + (A/2 - 2d)/6] \cdot [180 - (\hat{\alpha} + \theta + 90)] / 180$   
 $\hat{L}\hat{t} = Vr - (V\hat{t} + rt)$   
 where  $Vr = [(O\hat{A} + d)^2 + (B + OV)^2]$   
 $V\hat{t} = VE + d$   
 $rt = [(r\hat{r})^2 + (r\hat{t})^2 - 2r\hat{r} \cdot r\hat{t} \cdot \cos \psi]^{1/2}$   
 where  $r\hat{r} = (A/2 - 2d)/6$ ,  $r\hat{t} = d + (A/2 - 2d)/6$   
 $\hat{L}\hat{t} = 2T(VE + d) / 360$   
 Pore equivalent diameter = (Pore area  $\times 4$ ) / pore circumference ... (6)

### 2.3 Nonwoven Fabrics:

Poiseuille's law [9] for laminar flow through a straight circular capillary, which takes the form

$$q = \frac{\pi r^4 \Delta p}{8 \mu L}, \quad m^3/sec \quad \dots (7)$$

where  $q$  - rate of flow per one pore,  $m^3/sec$   
 $r$  - radius of the pore,  $m$   
 $L$  - overall length of the pore,  $m$   
 $\mu$  - air dynamic viscosity,  $Kg/m \cdot sec$   
 $\Delta P$  - Pressure drop across the length  $L, P_a$

Rate of flow per unit area (Q) can be calculated as follows:

$$Q = n \cdot q \quad , \quad m^3/m^2 \cdot \text{Sec} \quad \dots(8)$$

where n - number of pores per unit area

Equation (8) may be transformed into

$$Q = \pi d^4 \cdot n \cdot \Delta P / 128 \mu \cdot L \quad , \quad m^3/m^2 \cdot \text{Sec} \quad \dots(9)$$

where d = pore diameter , m

Equation (9) can be rewritten as follows:

$$Q = C \cdot \Delta P / \mu L \quad \dots(10)$$

where C - Proportionality constant

$$C = \pi d^4 \cdot n / 128 \mu \quad \dots(11)$$

$$\therefore \text{Porosity}(\varepsilon) = \pi d^2 \cdot n / 4 \quad \dots(12)$$

By substituting in Equation (11) from Equation (12)

$$C = d^2 \cdot \varepsilon / 32$$

Then Equation (10) can be rewritten as follows:

$$Q = d^2 \cdot \varepsilon \cdot \Delta P / 32 \cdot \mu \cdot L \quad , \quad m^3/m^2 \cdot \text{Sec}$$

or

$$d = (32 Q \cdot \mu \cdot L / \varepsilon \cdot \Delta P)^{1/2} \quad . \quad m \quad \dots(13)$$

A correction to Equation (13) is required to take into account the non-circular channels and the tortuosity of the stream lines which make varying angles with the direction of macroscopic flow.

Hence, pore equivalent diameter ( $d_e$ ) can be calculated as follows:

$$d_e = (32 Q \cdot \mu \cdot t \cdot K / \varepsilon \cdot \Delta P)^{1/2} \quad , \quad \dots(14)$$

where t - nonwoven fabric thickness, m

K - correction factor and is equal to 2.5.

### 3. MATERIALS AND METHODS

#### 3.1 Produced Fabrics:

By considering the previously mentioned variables which are likely to cause changes in fabric pore diameter and filtration efficiency, a total of twenty four woven, knitted and nonwoven filter fabrics was produced from different fibres. The characteristics of the various filter samples are listed in Tables I, II and III.

#### 3.2 Apparatus:

A photograph of the apparatus used is shown in Fig. 3 and the main features of the apparatus are shown in Fig. 4. The specimen holder consists essentially of a brass cylindrical vessel 1 over which the specimen 2 is clamped by a clamping ring 3 and screw 4. It is fitted with a rubber gasket 5 of 50 mm internal diameter to make a seal against the specimen. Circular specimens are clamped between rubber gaskets over the orifice. Compressed air enters the vessel through a tube B, thereby forcing air up against the specimen. Tube B is also connected to U-tube manometer D by means of a valve C and the pressure of air against the fabric is the pressure shown on the adjustable scale mounted on one arm of the manometer tube. The air supply for the test is drawn from a reservoir which is itself fed through a flow control device from a source (hydrostatic head tester) which may vary between 4 and 20

Table I: Characteristics of Woven Filter Fabrics

| Fabric No. | Weave design | Type of fibre | Fabric weight, g/m <sup>2</sup> | Fabric thickness, mm | Threads Per Inch |      | Yarn count, Ne |       | Cover Factor Kc |
|------------|--------------|---------------|---------------------------------|----------------------|------------------|------|----------------|-------|-----------------|
|            |              |               |                                 |                      | warp             | weft | warp           | weft  |                 |
| 1          | twill 2/2    | wool          | 505                             | 1.4                  | 38.1             | 34.3 | 3.467          | 3.99  | 25.08           |
| 2          | "            | "             | 394                             | 1.7                  | 35.6             | 33.0 | 4.83           | 3.45  | 23.69           |
| 3          | plain 1/1    | "             | 513                             | 0.6                  | 50.8             | 43.2 | 6.50           | 4.767 | 25.63           |
| 4          | twill 2/1    | "             | 544                             | 1.05                 | 36.8             | 34.3 | 3.37           | 3.18  | 25.51           |
| 5          | "            | cotton        | 357                             | 0.6                  | 94.0             | 51.0 | 8.07           | 1.17  | 26.58           |

Table II: Characteristics of Acrylic Knitted Filter Fabrics

| Fabric No. | Yarn Tex | Loop Length, cm | Wale Spacing, cm | Course Spacing, cm | Tightness Factor | Fabric Weight, g/m <sup>2</sup> | Fabric Thickness, cm | Fabric density, g/cm <sup>3</sup> |
|------------|----------|-----------------|------------------|--------------------|------------------|---------------------------------|----------------------|-----------------------------------|
| 1          | 4x21     | 1.010           | 0.360            | 0.166              | 9.074            | 484                             | 0.446                | 0.109                             |
| 2          | "        | 1.032           | 0.364            | 0.172              | 8.881            | 483                             | 0.463                | 0.104                             |
| 3          | "        | 1.069           | 0.372            | 0.183              | 8.573            | 469                             | 0.485                | 0.097                             |
| 4          | "        | 1.102           | 0.380            | 0.193              | 8.317            | 454                             | 0.494                | 0.092                             |
| 5          | 6x21     | 1.140           | 0.412            | 0.172              | 9.842            | 644                             | 0.529                | 0.122                             |
| 6          | "        | 1.178           | 0.428            | 0.181              | 9.525            | 630                             | 0.531                | 0.119                             |
| 7          | "        | 1.190           | 0.430            | 0.185              | 9.429            | 626                             | 0.550                | 0.114                             |
| 8          | "        | 1.260           | 0.434            | 0.203              | 9.107            | 603                             | 0.568                | 0.106                             |
| 9          | 8x21     | 1.335           | 0.492            | 0.197              | 9.708            | 717                             | 0.604                | 0.119                             |
| 10         | "        | 1.368           | 0.496            | 0.208              | 9.474            | 696                             | 0.620                | 0.112                             |

Table III: Characteristics of Nonwoven Filter Fabrics

| Fabric No. | Type of fibre                                      | Fabric Weight, g/m <sup>2</sup> | Fabric Thickness, mm | Fabric Density, g/cm <sup>3</sup> | Packing Density, |
|------------|--|---------------------------------|----------------------|-----------------------------------|------------------|
| 1          | 80% polyester/20% fibran                           | 346                             | 6.8                  | 0.0509                            | 0.0382           |
| 2          | "  | 1034                            | 8.2                  | 0.1261                            | 0.0947           |
| 3          | 33% wool/33% cotton/34% acrylic                    | 461                             | 5.25                 | 0.0878                            | 0.0665           |
| 4          | 40% acrylic/44% polyest/6% cotton/5% nylon/5% wool | 354                             | 5.4                  | 0.0656                            | 0.0513           |
| 5          | 80% polyester/20% fibran                           | 700                             | 6.2                  | 0.1129                            | 0.0848           |
| 6          | "  | 525                             | 5.4                  | 0.0972                            | 0.0730           |
| 7          | 100% polyester                                     | 325                             | 4.75                 | 0.0684                            | 0.0496           |
| 8          | 88% polyester/12% wool                             | 477                             | 4.4                  | 0.1084                            | 0.0791           |
| 9          | 70% polyester/30% cotton                           | 172                             | 3.0                  | 0.0575                            | 0.0432           |

lb/in<sup>2</sup>. The flow control device is designed to give the required rate of increase of pressure of 10 cm of water per minute, the rate of loading will be within the limits of  $10 \pm 0.5$  cm/min up to the limit of the apparatus. The maximum head attainable is 150 cm of water.

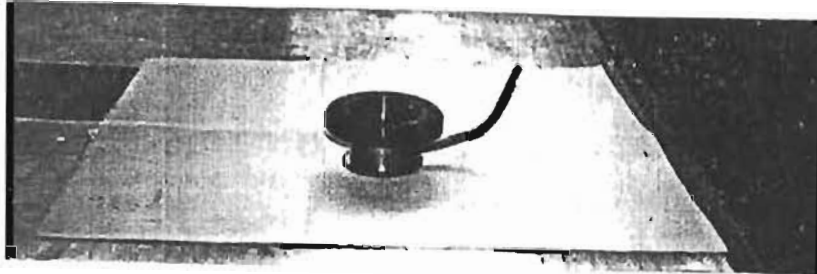

Fig. 3. Photograph of the apparatus

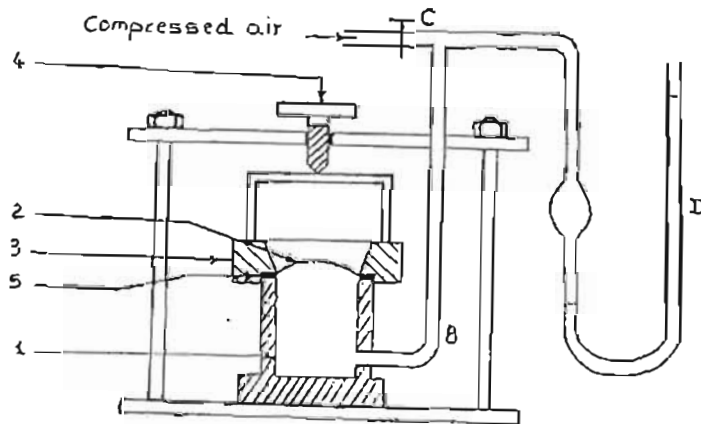

Fig. 4. Schematic diagram of the apparatus

**Test Procedure :** A circular specimen 6 cm in diameter, is conditioned at 65 per cent r.h. and 20 C, and then completely immersed and soaked for three minutes in white alcohol. After soaking, it is mounted on the testing head of the apparatus and the upper surface is covered with white alcohol. The air pressure is raised on the under surface, at a rate of increase of pressure of 10 cm head of water per minute, until streams of bubbles appear at three places in the specimen, this pressure,  $P_b$ , in cm of water is then noted. Ten specimens are tested and the equivalent diameter of the third largest pore in the specimen,  $d_e$ , is calculated for each specimen from the formula [6].

$$d_e = 4 S \times 10^4 / P_b \cdot g \quad \dots(15)$$

Where  $S$  is the surface tension of the white alcohol in dynes per cm at the temperature at which the test is carried out and  $g$ , the acceleration of gravity, is taken as 981 cm/sec<sup>2</sup>. The mean equivalent pore diameter is then calculated for the fabric.

4. RESULTS AND DISCUSSION

Pore equivalent diameter ( $d_e$ ) of woven, knitted and nonwoven filter fabrics could be calculated using Equations (3), (6) and (14) respectively. Also it could be measured by means of bubble-pressure method. The results are listed in Tables IV, V and VI.

When using both harmonic mean method (H) and specific surface method (D) for calculating pore equivalent diameter in woven fabrics it could be noticed that the deviation between calculated and measured values is minimum. Thus it is preferable to use harmonic mean method and specific surface method for calculating pore equivalent diameter of woven and knitted fabrics respectively. In woven fabrics, the harmonic mean method selected for calculating pore diameter agrees with the findings of a previous investigator. [5].

The comparison between both calculated and measured values has been possible. The good agreement shown by Tables IV, V and VI support the validity of the derived Equations (3), (6) and (14) at least within the range of material and fabric characteristics used.

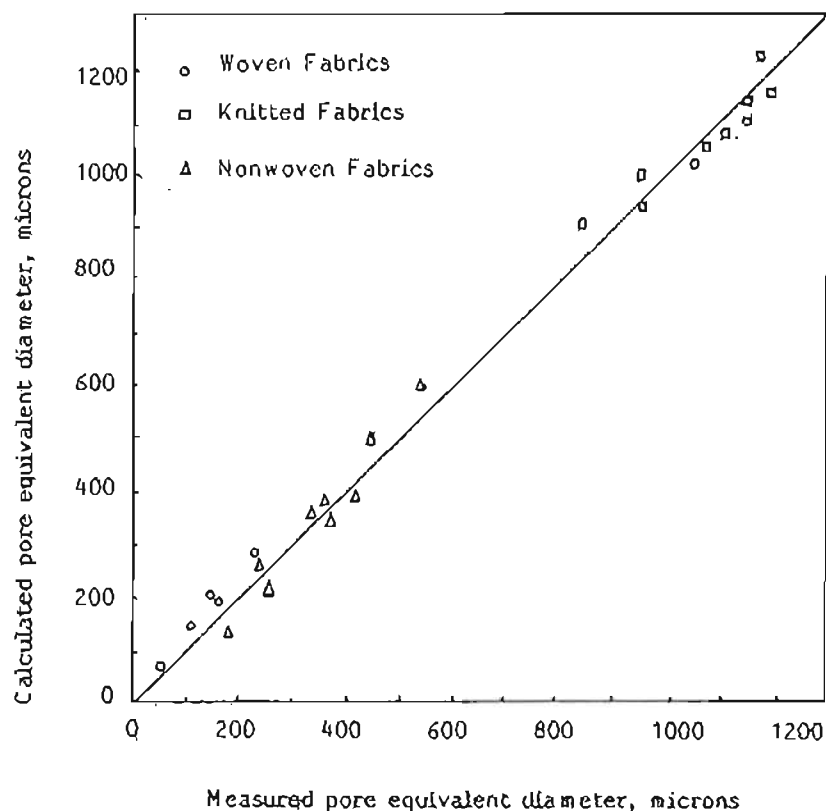

Fig. 5. Comparison between measured and calculated pore equivalent diameter of woven, knitted and nonwoven fabrics.



Table IV : Typical Results of Woven Filter Fabrics

| Fabric No. | Warp Spacing, $a_0$ , mm | Weft Spacing $b_0$ , mm | Pore Equivalent Diameter, microns |          |            |          |            | Measured |
|------------|--------------------------|-------------------------|-----------------------------------|----------|------------|----------|------------|----------|
|            |                          |                         | Calculated By                     |          |            |          |            |          |
|            |                          |                         | Method A                          | Method G | Method (H) | Method E | Method (D) |          |
| 1          | 0.1607                   | 0.2687                  | 214.7                             | 207.8    | 201.1      | 214.7    | 201.1      | 176.0    |
| 2          | 0.2843                   | 0.2622                  | 273.3                             | 273.0    | 272.8      | 271.5    | 272.8      | 234.7    |
| 3          | 0.1300                   | 0.1546                  | 142.3                             | 141.8    | 141.2      | 141.4    | 141.2      | 117.3    |
| 4          | 0.1765                   | 0.2100                  | 193.3                             | 192.5    | 191.8      | 192.1    | 191.8      | 162.5    |
| 5          | 0.0466                   | 0.1061                  | 76.4                              | 70.3     | 64.8       | 76.3     | 64.8       | 62.1     |

$$A = (a_0 + b_0) / 2, \quad G = (a_0 \cdot b_0)^{0.5}, \quad H = 2 / (1/a_0 + 1/b_0)$$

$$E = L_n [ 0.5(e^{a_0} + e^{b_0}) ], \quad D = 4(a_0 \cdot b_0) / (a_0 + b_0)$$

Table V : Typical Results of Knitted Filter Fabrics

| Fabric No. | Fabric Porosity | Pore Area, cm <sup>2</sup> | Pore Circumference, cm | Pore Equivalent Diameter, microns |          |
|------------|-----------------|----------------------------|------------------------|-----------------------------------|----------|
|            |                 |                            |                        | Calculated                        | Measured |
| 1          | 0.9068          | 0.010858                   | 0.488458               | 889.2                             | 845      |
| 2          | 0.9111          | 0.011617                   | 0.469902               | 988.9                             | 961      |
| 3          | 0.9171          | 0.014060                   | 0.526761               | 1067.7                            | 1113     |
| 4          | 0.9214          | 0.015588                   | 0.550334               | 1132.9                            | 1149     |
| 5          | 0.8957          | 0.012644                   | 0.544128               | 929.5                             | 961      |
| 6          | 0.8983          | 0.013909                   | 0.551188               | 1009.4                            | 1057     |
| 7          | 0.9026          | 0.015686                   | 0.559293               | 1038.6                            | 1078     |
| 8          | 0.9094          | 0.017101                   | 0.560680               | 1220.0                            | 1174     |
| 9          | 0.8983          | 0.020325                   | 0.738949               | 1100.2                            | 1149     |
| 10         | 0.9043          | 0.020951                   | 0.726973               | 1152.8                            | 1201     |

Table VI : Typical Results of nonwoven filter Fabrics

| Fabric No. | Porosity, $\epsilon$ | Air Permeability       |                 | Pore Equivalent Diameter, microns |          |
|------------|----------------------|------------------------|-----------------|-----------------------------------|----------|
|            |                      | $Q, m^3/m^2 \cdot Sec$ | $\Delta P, P_a$ | Calculated                        | Measured |
| 1          | 0.9618               | 0.18146                | 14.7            | 372.09                            | 365.8    |
| 2          | 0.9053               | 0.18146                | 19.8            | 364.74                            | 354.7    |
| 3          | 0.9335               | 0.10848                | 49.0            | 140.54                            | 193.3    |
| 4          | 0.9487               | 0.18935                | 24.5            | 264.17                            | 252.4    |
| 5          | 0.9152               | 0.17751                | 39.2            | 220.60                            | 265.6    |
| 6          | 0.9270               | 0.19724                | 7.35            | 498.00                            | 449.9    |
| 7          | 0.9504               | 0.19329                | 9.80            | 395.40                            | 419.5    |
| 8          | 0.9209               | 0.15779                | 9.80            | 349.34                            | 368.8    |
| 9          | 0.9568               | 0.17751                | 2.45            | 600.30                            | 542.9    |

Figure 5 shows both measured and calculated values for the tested filter fabrics. It can be seen that the theoretical relations obtained in the work discussed in this paper can be therefore considered to agree fairly close with the obtained experimental results.

### 5. CONCLUSIONS

From the above analysis the following conclusions can be drawn:

1. In this paper a new simple and still efficient apparatus was established by the author for measuring pore equivalent diameter of filter fabrics using bubble-pressure method.
2. The theoretical relations of pore diameter for woven, knitted and nonwoven filter fabrics obtained in the work discussed in this paper can be therefore considered to agree fairly close with the obtained experimental results.

### REFERENCES

1. Kondratyck E.V., The determination of interyarn pore sizes of surface porosity of fabrics and knitted goods by the method of geometrical probabilities, Technology of Textile Industry, 1972, No.6, P.44-47.
2. Bartell F.E. Private communication to the late Dr. F.T. Peirce of the Shirley Institute.
3. Lord J. and Taylor H.M. The bubble pressure test for the measurement of the pore size of fabrics-part I: The development of the test. J. Text. Inst., 1954, Vol. 45, No. 4, T.371-379.
4. Cevactanova A.G. The determination of pore size of felted filter fabrics. Textile Industry, 1971, No. 5, P.20-22.
5. Jokhena E.A., Ph.D. Thesis, Moscow Textile Institute, Moscow, 1984.
6. Joan Lord. The bubble pressure test for the measurement of the pore size of fabrics-part II : The application of the bubble pressure test to a study of the sealing of close cotton cloths when wetted. J. Text. Inst., 1954, Vol. 45, P.380-389.
7. Standardisation. Method of test for the measurement of the pore size of fabrics (bubble pressure test). J. Text. Inst., 1959, Vol. 50, P.763-771.
8. Kykin C.N. and Salaveov A.N. Science of Textile Materials-part III., 1967.
9. Traekof B.S. and kykin G.N. An equipment for testing hydrodynamic resistance of textile materials. Technology of Textile Industry, 1984, No.3, P.7-9.